





scalarmisation nonoctaviante libre

16 phrases d'LLL de La Langue des Lignes pour musique :
destinées au quatuor à cordes acoustique et électrique
 sans "se prendre au sérieux" ni "dramatiser" :(
 mais dans un état d'esprit taquin espiègle :)

string 1 = 
 string 2 = 
 string 3 = 
 string 4 = 

EST-CE QUE CA
 SE MANGE?

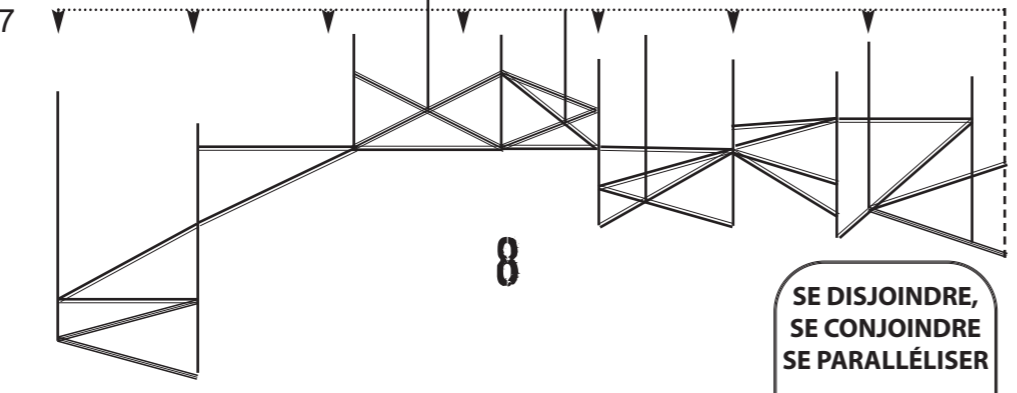
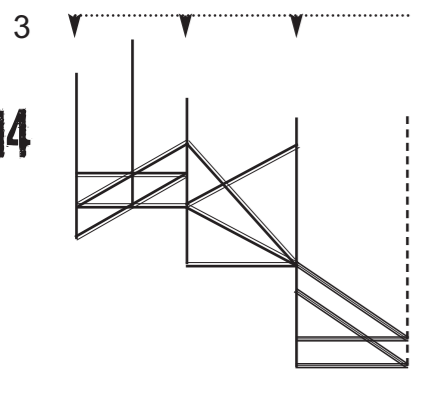
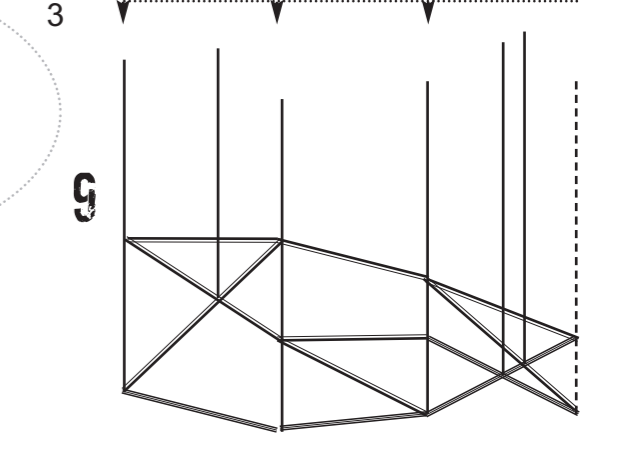
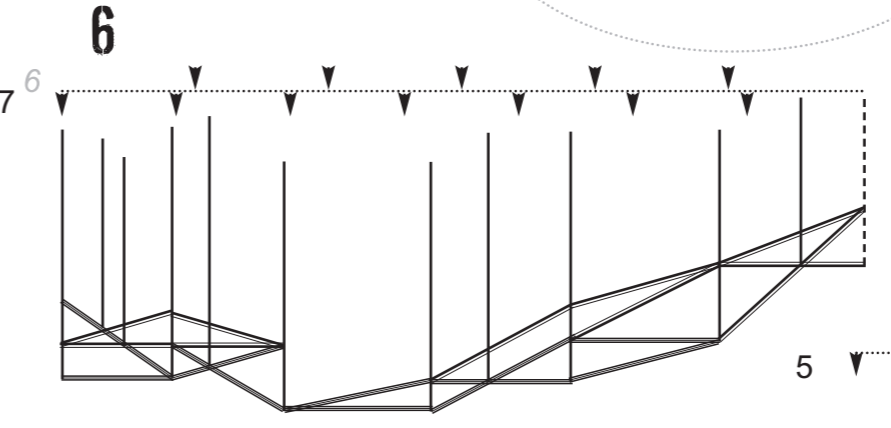
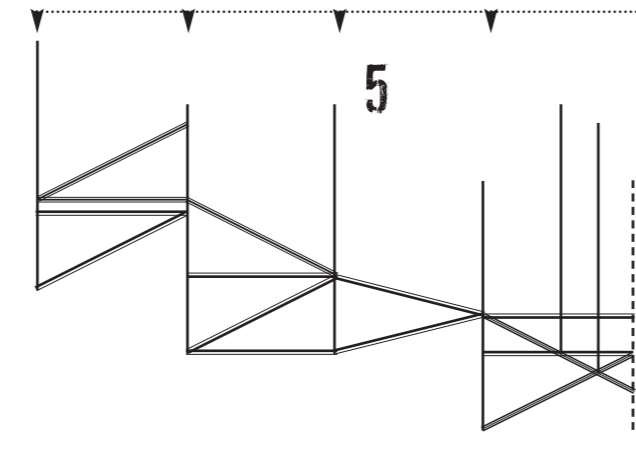
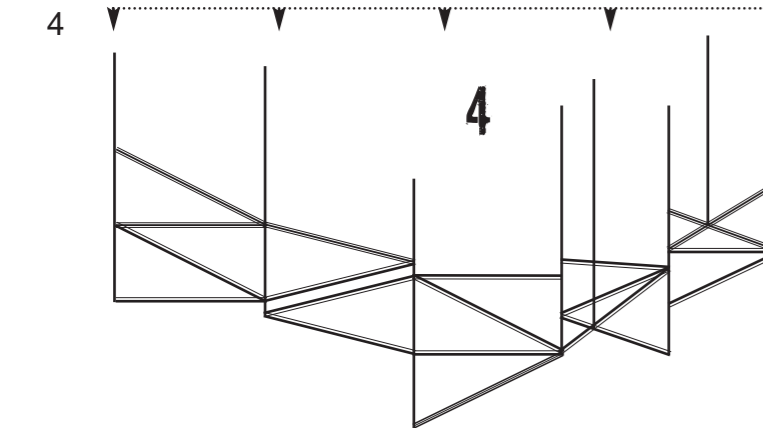
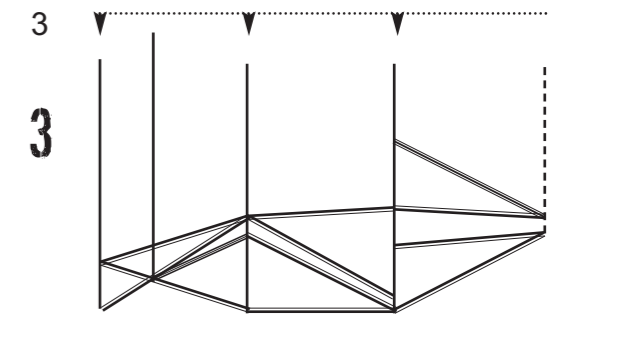

**SE DISJOINDRE,
 SE CONJOINDRE
 SE PARALLÉLISER**

entraînement
 de **disjonction**
 (quitter l'unisson
 = éloignements),
 de **conjonction**
 (joindre l'unisson
 = rapprochements)
 et
 de **côtoiement**
 (rester côte à côte
 sans se toucher)

